

TIMMY FOLDING & PLUS
215P

DESCRIPTION / DESCRIZIONE

en Timmy is a modular, space saving table system, ideal for conference, meeting and seminar rooms. The version with folding legs retains the clean design characteristics of Timmy collection thanks to the intuitive control system integrated into the structure. The new Plus accessory makes it easy to join two tables with a straight or corner top, increasing the possibilities of configurations while limiting the number of structures used. A robust table for an easy reorganisation of the spaces.

it Timmy è un sistema di tavoli modulari e salvaspazio, ideali per l'allestimento di sale conferenze, riunioni e seminari. La versione Folding, con gambe pieghevoli, mantiene il design pulito identificativo della collezione Timmy grazie all'intuitivo sistema di comando integrato nella struttura. Il nuovo accessorio Plus permette con facilità di unire due tavoli con piani rettilinei o ad angolo aumentando le possibilità di configurazione, contenendo il numero di strutture utilizzate. Un tavolo robusto che permette di riorganizzare gli ambienti con facilità.

TIMMY FOLDING & PLUS
multifunctional and space saving table, with folding legs
tavolo multifunzionale e salvaspazio, con gambe pieghevoli

215P

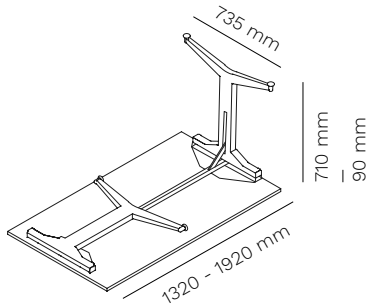

top
1400 - 2000 x 800 - 1000 mm

PLUS R0

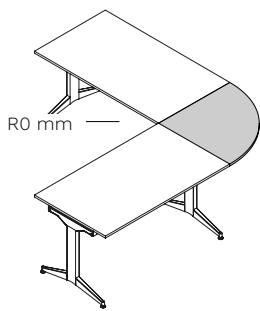

top
800 mm

PLUS R400

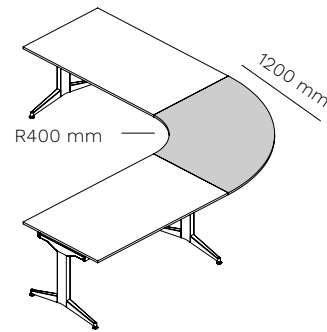

top
800 mm

PLUS 1400 / 1800

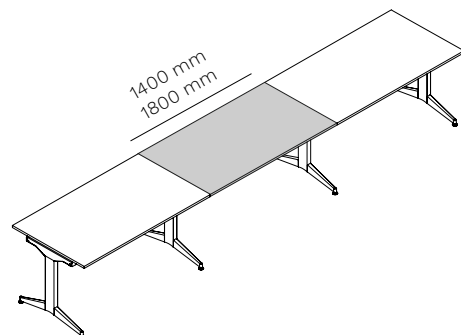

top
1400 - 1800 x 800 - 1000 mm



stackable
impilabile



version with FSC® certified top
versione con piano certificato FSC®



2 LEGS 2 GAMBE	9 Kg	1 pc 0,73 mc	27 pcs / EU pallet 80x120x230h cm
1 BEAM 1400 - 1600 mm 1 TRAVERSA 1 400 - 1600 mm	6 kg	1 pc 0,39 mc	50 pcs / EU pallet 135x110x190h cm
1 BEAM 1800 - 2000 mm 1 TRAVERSA 1800 - 2000 mm	8 Kg	1 pc 0,50 mc	2 pcs / EU pallet 175x110x190h cm

SOME POSSIBLE CONFIGURATIONS / ALCUNE POSSIBILI CONFIGURAZIONI

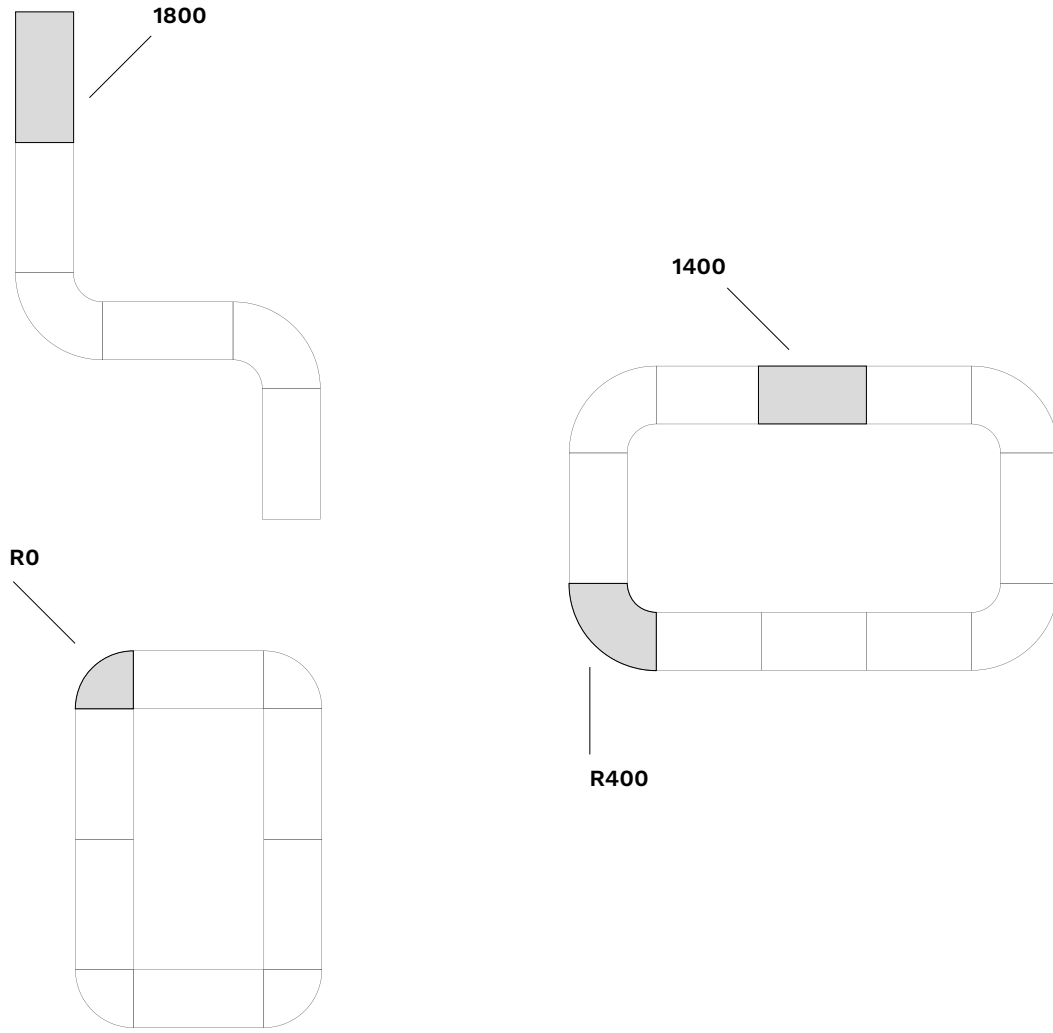

LEGEND / LEGENDA

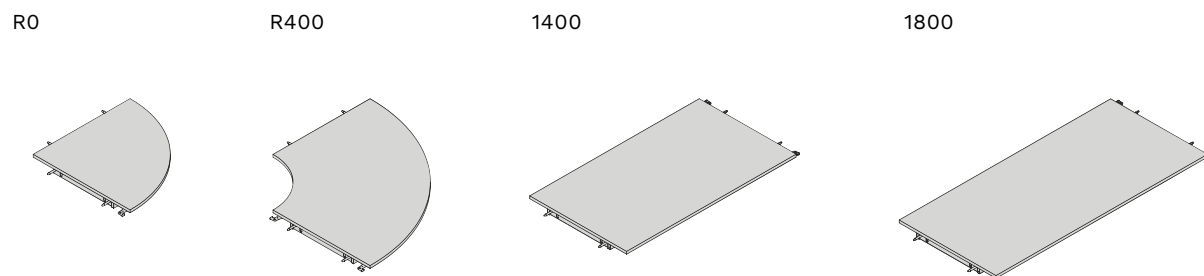

TIMMY FOLDING & PLUS 215P

mara

INCLUDED ACCESSORIES / ACCESSORI INCLUSI

215KIT



nylon kit for connection
agganci in nylon

only for R0, R400, 1400, 1800
solo per R0, R400, 1400, 1800

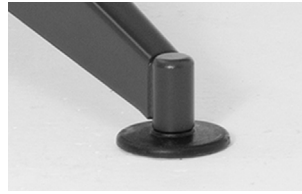

foot levelers
piedini livellatori

ACCESSORIES / ACCESSORI

511PLUS



top access with flip cover
passacavi con sportello

350P



plastic cables-fixer for table top
portacavi in plastica per piano

300

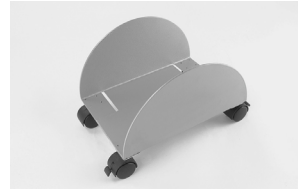

cpu holder
portaserver

500DROLL



mobile storage system, on castors
cassettiera mobile su ruote

200 - 202



trolley
carrello

VERTEBRE



Flexible cable management
Vertebra flessibile in rete

FRAME / STRUTTURA

powder coated steel and chromed steel
acciaio verniciato e acciaio cromato



TOP / PIANO

standard colour and material effect laminate tops
piani standard in laminato colore ed effetto materico



STANDARDS AND CERTIFICATES / NORME E CERTIFICATI
Dimensional tolerance related to the thickness $\pm 0,3$ mm •
Dimensional tolerance related to the sizes $\pm 5,0$ mm • Resistance to scratching EN 438-2:2016 Class 3 • Resistance to staining EN 438-2:2016 Group 1 e 2: Class ≥ 4 Group 3: Class ≥ 4 • Resistance to dry heat (160°C/20') - EN 438-2 Class 4 • Lightfastness (xenon arc) EN 438-2 Grayscale classification ≥ 4

• Resistance to steam EN 438-2 Class 4 • Resistance to surface wear EN 438-2 Rotation value IP ≥ 150 • Resistance to damp heat (100°C/20') - EN 438-2 Class 4

TOP / PIANO

standard colour and material effect melamine tops
piani standard in nobilitato colore ed effetto materico



white
bianco



magnolia



light grey
grigio
chiaro



anthracite
antracite



black
nero



whitened oak
rovere
sbiancato



natural oak
rovere
naturale



grey oak warm
rovere
grigio warm



walnut
noce



cement
cemento



iron
ferro

STANDARDS AND CERTIFICATES / NORME E CERTIFICATI
Dimensional tolerance related to the sizes $\pm 5,0$ mm • Resistance to scratching 1,5 N • Resistance to cigarette burning 3 grade - moderate change in gloss level and/or moderate brown spots • Resistance to surface wear Rotation value IP < 50 Rotation value WR < 150 • Risk of breakage ≥ 3 group • Dimen-

sional tolerance related to the thickness $15 \leq X \leq 20$ mm : $\pm 0,3$ mm X < 20 mm : $\pm 0,5$ mm • Resistance to staining ≥ 3 group • Resistance to steam 4 grade - moderate change in gloss level and/or color • Surface imperfections Prolate imperfections: < 20 mm/m Punctiform imperfections: < 2 mm²/m² • Lightfastness (xenon arc) > 6 group

CLEANING AND MAINTENANCE / PULIZIA E MANUTENZIONE

STEEL / ACCIAIO

en Our types of metals include: chromed metals and painted metals. Do not use acid or alkaline based cleaning products. Do not use detergents, steel wool, dishwashing detergents or the like. Sharp or pointed objects may damage the surface. Any hot or wet object may cause surface damage. Clean the surface regularly with a soft cloth to remove dust. To remove light dirt, use a soft cloth and a neutral household cleaner.

it Le nostre tipologie di metallo comprendono: metalli cromati e metalli verniciati. Non utilizzare prodotti per la pulizia a base acida o alcalina. Non utilizzare detergenti, lana di acciaio, detersivi per stoviglie o simili. Oggetti appuntiti o taglienti possono danneggiare la superficie. Qualsiasi oggetto caldo o bagnato potrebbe provocare danni alla superficie. Pulire la superficie regolarmente con un panno soffice per rimuovere la polvere. Per rimuovere lo sporco leggero utilizzare un panno soffice e un prodotto per le pulizie di casa neutro.

CHROMED STEEL AND ALUMINIUM POLISHED / ACCIAIO CROMATO E ALLUMINIO LUCIDO

en Do not use acid or alkaline based cleaning products. Do not use detergents, steel wool, dishwashing detergents or the like. Sharp or pointed objects may damage the surface. Any hot or wet object may cause surface damage. Clean the surface regularly with a soft cloth to remove dust. To remove light dirt, use a soft cloth and a neutral household cleaner

it Non utilizzare prodotti per la pulizia a base acida o alcalina. Non utilizzare detergenti, lana di acciaio, detersivi per stoviglie o simili. Oggetti appuntiti o taglienti possono danneggiare la superficie. Qualsiasi oggetto caldo o bagnato potrebbe provocare danni alla superficie. Pulire la superficie regolarmente con un panno soffice per rimuovere la polvere. Per rimuovere lo sporco leggero utilizzare un panno soffice e un prodotto per le pulizie di casa neutro.

LAMINATE AND MELAMINE / LAMINATI E NOBILITATI

en Laminates and melamine products guarantee high performance in terms of resistance to scratches, shocks and abrasions. Keep furniture away from direct sunlight; furniture in direct sunlight may tend to discolour over time. Do not use acid or alkaline based cleaning products. Sharp or pointed objects can damage the surface. Laminate and melamine furniture can be cleaned using a mixture of liquid soap and hot water. Rinse with cold water and dry with a paper towel or damp cloth.

it Laminati e nobilitati garantiscono alte prestazioni di resistenza ai graffi, agli urti e alle abrasioni. Mantenere i mobili lontani dalla luce diretta del sole; i mobili che si trovano alla luce diretta del sole potrebbero tendere a scolorire nel tempo. Non utilizzare prodotti per la pulizia a base acida o alcalina. Oggetti appuntiti o taglienti possono danneggiare la superficie. E' possibile effettuare la pulizia dei mobili in laminato e nobilitato usando una miscela di sapone liquido e acqua calda. Sciacquare con acqua fredda e asciugare con un tovagliolo di carta o un panno umido.

KIT OF NYLON LINKS/HOOKS FOR TOP CONNECTION

KIT AGGANCI IN NYLON PER COLLEGAMENTO PIANI

mara

215KIT

DESCRIPTION / DESCRIZIONE

en Nylon kit that makes it easy to connect two tables.

it Kit agganci in nylon che permette con facilità di unire due tavoli.

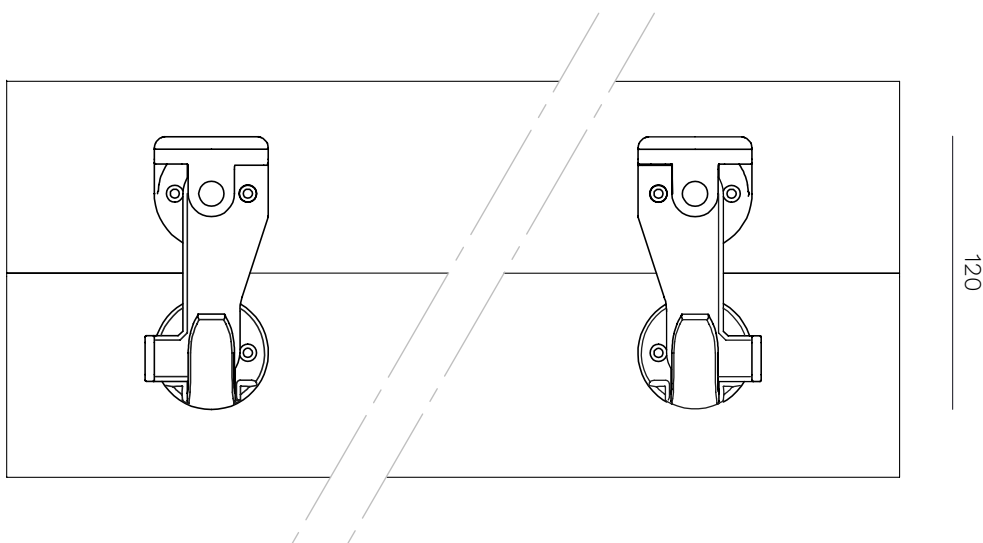

Drilling pattern:

Schema di foratura:

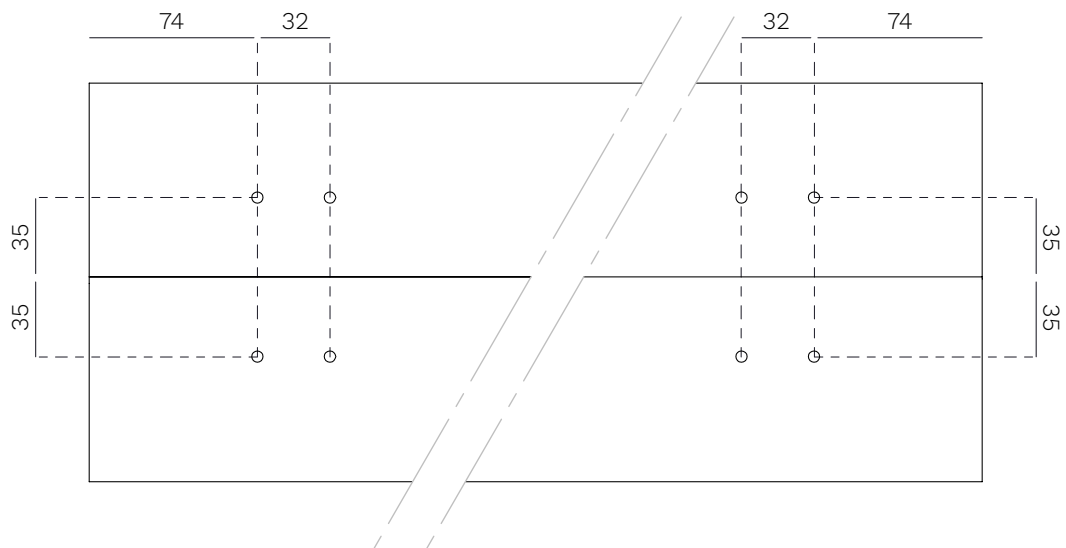

All measurements are indicated in mm
Tutte le misure sono indicate in mm

COLOURS AVAILABLE / COLORI DISPONIBILI



black
nero



TOP ACCESS

PASSACAVI

511PLUS

mara

DESCRIPTION / DESCRIZIONE

en Aluminium top access with flap. Black brush.

it Passacavi in alluminio con spazzola nera.



1

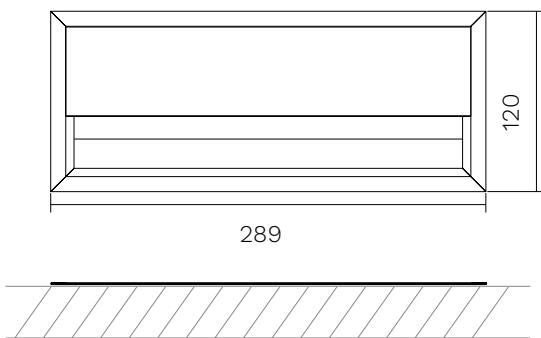

All measurements are indicated in mm
Tutte le misure sono indicate in mm

Surface cut-out area

Area di taglio della superficie



COLOURS AVAILABLE / COLORI DISPONIBILI



aluminium
alluminio



black
nero



TROLLEY
CARRELLO

200

mara

DESCRIPTION / DESCRIZIONE

en Steel trolley with 4 castors of Ø 100 mm diameter for transporting tables and folding legs.

it Carrello in acciaio con 4 ruote di Ø 100 mm per il trasporto di tavoli e gambe pieghevoli.

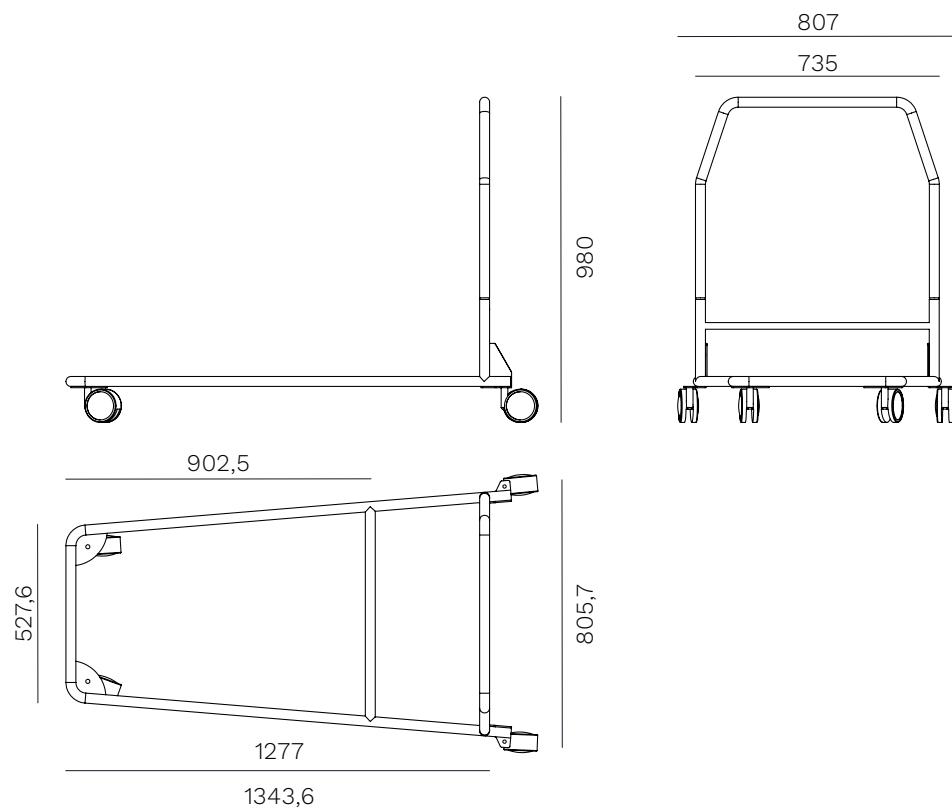

All measurements are indicated in mm
Tutte le misure sono indicate in mm

AVAILABLE FINISHES / FINITURE DISPONIBILI

powder coated steel
acciaio verniciato



TROLLEY
CARRELLO

202

mara

DESCRIPTION / DESCRIZIONE

en Steel trolley with 4 castors of Ø 125 mm diameter for transporting tables and folding legs.

it Carrello in acciaio con 4 ruote di Ø 125 mm per il trasporto di tavoli e gambe pieghevoli.

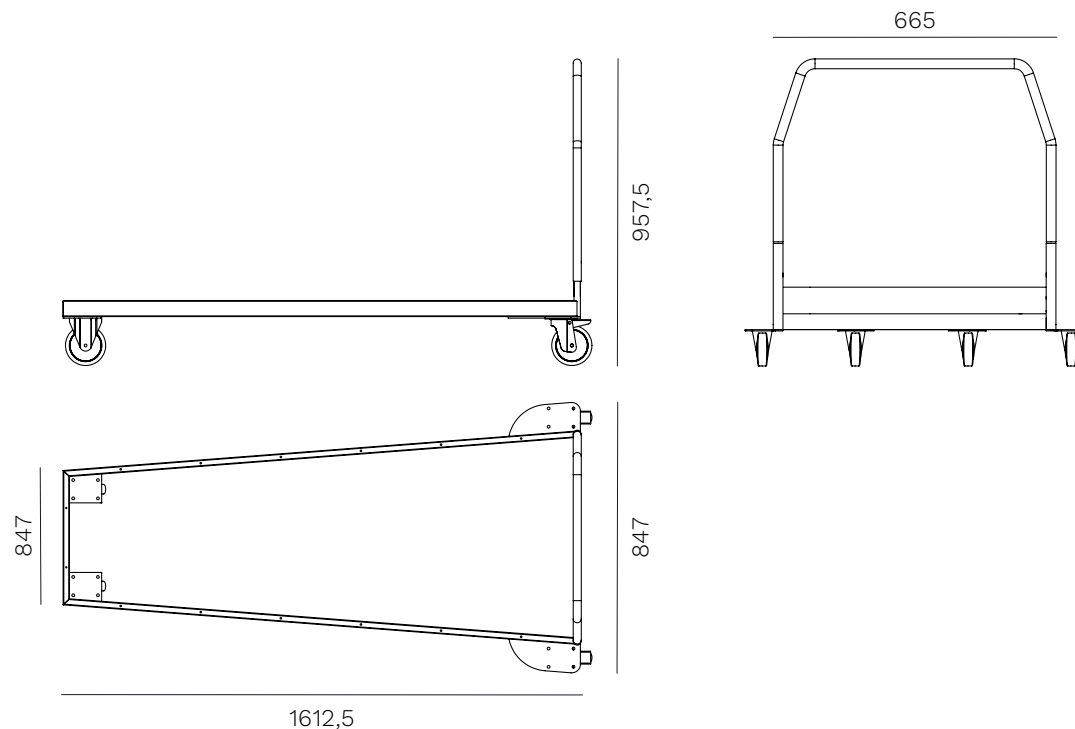

All measurements are indicated in mm
Tutte le misure sono indicate in mm

AVAILABLE FINISHES / FINITURE DISPONIBILI

powder coated steel
acciaio verniciato

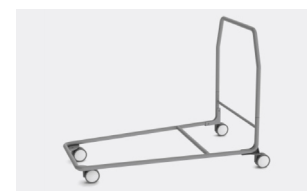

FLEXIBLE CABLE MANAGEMENT

VERTEBRA FLESSIBILE IN RETE

VERTEBRE

mara

DESCRIPTION / DESCRIZIONE

en Flexible cable duct made of multifilament polyester, double slider zip, max. height 1300 mm, suitable for height-adjustable tables, complete with tabletop mounting plate and base with weight for greater stability

it Canalina flessibile realizzata in poliestere multifilamento, cerniera con doppio cursore, altezza max. 1300 mm, adatta a tavoli regolabili in altezza, completa di piastra di fissaggio al piano e base con peso per maggiore stabilità

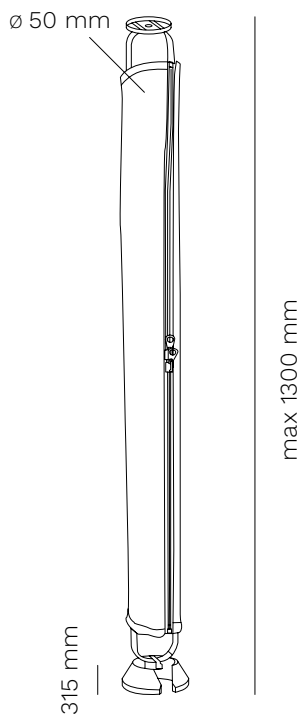

- Suitable for height-adjustable tables
- For table tops with a maximum height of 1300 mm
- Hinge with two sliders for opening from both the top and bottom
- Easy to attach to the table top with a single screw (included)
- Versatile thanks to the flexibility of the fabric

- Adatta a tavoli regolabili in altezza
- Per piani tavolo con altezza max. 1300 mm
- Cerniera con due cursori per apertura sia dall'alto che dal basso
- Fissaggio facilitato al piano tramite una sola vite (inclusa)
- Versatile grazie alla flessibilità del tessuto

Flexible multi-filament polyester fabric

Tessuto flessibile in poliestere multifilamento



Black
nero



aluminium
alluminio



white
bianco

en As it is always seeking to improve its products, the company reserves the right to modify or upgrade the products without prior notice, at any time. Colors should be considered purely indicative. Mara's Collections are worldwide protected by the industrial property right and patents.

it Mara, sempre alla ricerca del miglioramento dei propri prodotti, si riserva la facoltà di apportare modifiche costruttive e funzionali in qualsiasi momento senza alcun preavviso. I colori dei materiali sono da ritenersi puramente indicativi. Tutte le collezioni Mara sono protette nel mondo dal diritto di proprietà industriale e da brevetti registrati.